

# Rotator FR 15 FM

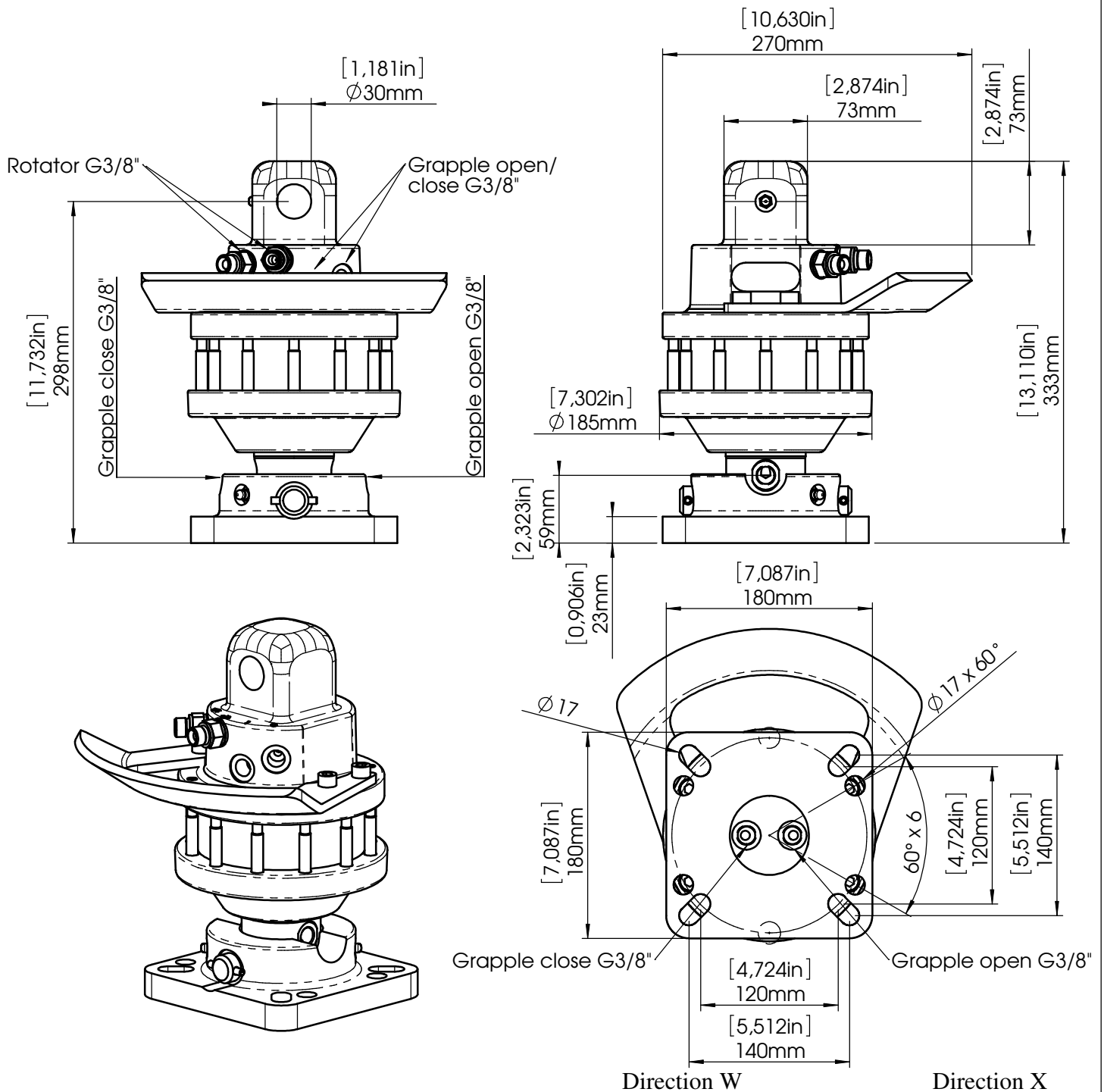

FR 15 FM	
Rotation angle	Unlimited
Max. working pressure	200 bar
Displacement	464 cm <sup>3</sup>
Torque (200 bar)	1150 Nm
Max. axial force	82 kN
Safe working load	5500 kg
Weight	34 kg

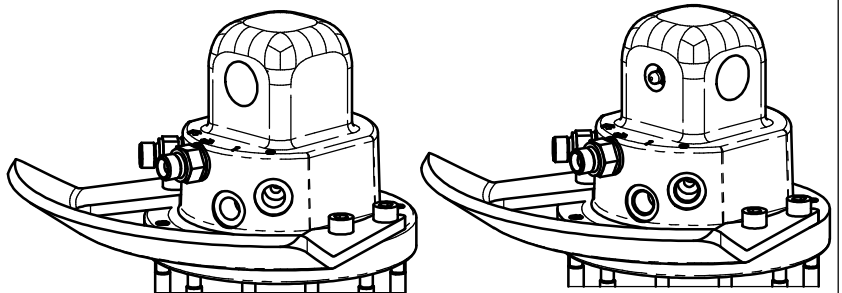

Basic models				
Item	Name	Direction	D1	Flange
11518	FR 15-X30FM	X	30	FM
11515	FR 15-W30FM	W	30	FM

Flange connections: D173, 120x120, 140x140